

MS122402 BACKUP SYSTEM INSTRUCTIONS MANUAL

1. PRELIMINARY INFORMATIONS

Manufacturer : elc 59, avenue des Romains 74000 ANNECY-FRANCE
 Phone : +33 (0)4 50 57 30 46 Fax : +33 (0)4 50 57 45 19
 Instrument : UNIVERSAL MO-
 DULE
 Brand : elc
 Type : MS122402

2. DESCRIPTION

2-1 Introduction

You have purchased a MS122402 backup system. We thank you and congratulate you for your good choice.

This device was manufactured in accordance with European standard EN 60950 and was supplied in good conditions. This instrument is intended to professional, and industrial uses for fixed installations. This instructions manual contains informations and warnings the buyer must comply with in order to ensure safe and sustained operation.

Adding the backup system MS122402 with a Lead-acid battery charger 12V or 24V to a DC 12V or 24V power supply, it modifies this one in an uninterrupted power supply (Power Supply Safety). No swithching is required between a 12V or 24V system; the backup system MS122402 detects automatically the voltage of battery and power supply and it adapts accordingly.

The MS122402 block is protected against battery reverse polarity and overcurrent.

Charging current of the battery is adjustable from 0,3 A to 2 amps

Dry contacts are available for Rest / Work for "Battery Failure" & "No Main".

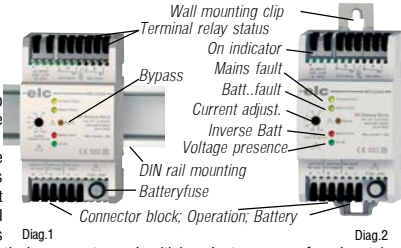

2-2 Overall view (see above Feature 1 & 2)

2-3 Technical specifications at 23°C.

		12 Volts system	24 Volts system
Input voltage	mini to max	10 V to 14,1 V	20 V to 28,2 V
Output voltage	normal operation	13,5 V to 13,8 V	27 V to 27,6 V
	safety operation	13,8 V to 10,3 V	27,6 V to 20,6 V
Batteries (not included)	Sealed lead	12 V	24 V
	Allow capacity	2 Ah to 20 Ah	
Batteries charge	Current limitation	Adjustable from 0,3 A to 2 A	
Mains	Sector supervision	230 V ; 0,2 W ; 50-60 Hz	
Functions	Sector absence detection	195,5 V > Udétection > 170 V	
	Overload protection	14,5 V	29 V
	Batt.overcurrent protection	10 Amps Rapid fuse	
	Batt.inverse protection	Yes (LED indicator red)	
	Emergency stop	10,3 V	20,6 V
	Current shutdown state	80 µA	160 µA
	By-Pass function	Yes	
	Voltage presence	Yes (LED indicator green)	
	Battery fault charge	Yes (LED indicator yellow)	
	Sector presence fault	Yes(LED indicator yellow)	
	Report failure load	Yes (Relay 1RT ; 250 VAC ; 30 VDC)	
	Report mains failure	Yes (Relay 1RT ; 250 VAC ; 30 VDC)	

Environmental conditions : of use : 5 °C a +50 °C.
 moisture 50 to 85%.
 Storage : -10 °C to + 85 °C, unless ice and condensation
 Protection level : IP 30
 Insulation class : II
 Safety standard : EN 60950 ; according to § A4-A6 of the standard NF S 61-940
 EMC standard : EN 61000-6-2:2001, EN 61000-6-4:2001
 Presentation : modular case (3 modules) in polyamide PA, screenprinted.
 Dimensions / Weight : h = 95 mm l = 54 mm p = 58 mm ; Weight: 163 g
 Connections : screw terminal blocks for 2.5mm² wire (AWG12)

3. WORKING

3-1 Safety instructions

Only qualified people should work on this device or in its neighbourhood.

In order to avoid electric shocks, this device should not be accessible under normal operation. (Installation must be done in electrical equipment box or in a closed box...).

Before installation or maintenance, the main circuit breaker should be open and condemned to forbid its inopportune closing.

The 230V input, for mains mesure, will be taken on the line circuit breaker planned for the DC system 12 or 24V. A circuit breaker must be included in the electrical installation close to the instrument and must be easily accessible by the operator.

For a natural and correct cooling, the instrument must be installed vertically and all openings must be widely cleared.

Voltage supply recommended for lead-acid batteries charge : to maintain a lead-acid battery correctly charged, the floating voltage corresponds at 2,275V by element at 20°C. So be it 13,65V for a 12V battery or 27,3V for a 24V battery.

Any deviation from this point reduces life durability; refer to manufacturer curves.

3-2 Mounting

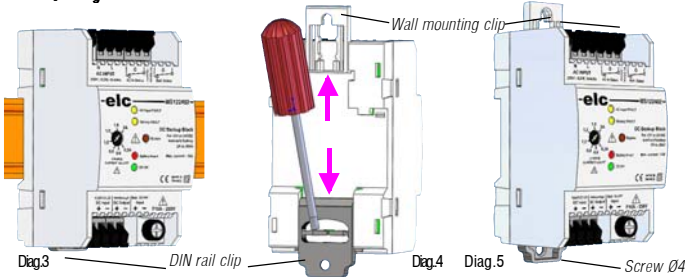

Mounting by CLIP on the profiled 35x15mm or 35x7,5mm (DIN rail EN 50022) :

- Engage the hooks on the top of the rail and push the power supply against the rail in order to lock the hook (push it back if necessary). (diagram 3).

To take it off, introduce a screwdriver into the part of the hook located under the power supply and push it toward the bottom and take it off, rocking it toward the top.

Wall mounting :

- Push strongly the mounting clip to lock it in a high position (diagram 4)

- Push the DIN rail clip toward the bottom lifting the two parts with a screwdriver in order to move its place (diagram 4).

- Fix the power supply with two screws of Ø4 mm in the clip holes (diagram 5).

3-3 Connection and operation

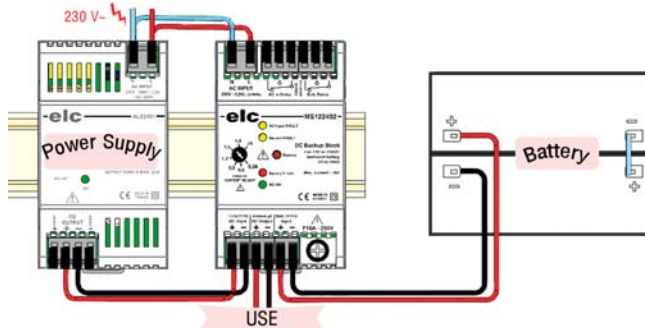

Connect the use in the terminal block "Uninterrupt DC Output", Positive left, negative right.

Adjust battery current load at approximately 1/10 of its capacity (for example 1A for 10Ah) and connect the battery in the terminal block "Batt 12/24 V Input" Positive wire left, negative wire right.

Connect the terminal block "DC Input" in the power supply output set to 13,6 V for a battery of 12V or 27,2V for a battery of 24V. This power supply must provide in addition to current use, the battery current. Connect the terminal block "AC input" to 230 V below the breaker feeding.

Engage 230V, after two seconds, relay stick and only the lead "DC OK" should be lightening.

The supply voltage is present on the terminal "uninterruptable DC Output".

If the values of battery voltage and power supply are correct, the backup system MS122402 configures itself in battery charger with limited current (the one previously adjusted between 0,3 and 2A in front).

The illumination of the led "Battery FAULT" indicates that the voltage is not consistent with the battery or the battery is unusable.

Attention : This device is not a charger, it produces a trickle charge. In case of installation of a battery deeply discharged, it is advise to recharge it before.

Sector absence test : Cut the sector (there's no charge), the led "AC Input FAULT" lights up. The battery took over in automatic without interruption and supplies operation. Re-start the sector, the led lights off, the power supply provides the current operation and the MS122402 remains in battery charger.

Battery fault test : Disconnect one of the two poles of the battery 12 or 24V or remove the fuse, the led "Battery FAULT" lights up. Reconnect the battery the led lights off.

4. UTILISATION

4-1 "AC Input FAULT"

Sector absence, the led "AC Input FAULT" lights up : when voltage in the terminal block "AC INPUT" is lower than 0,8 x Un, be it 184V rms (195,5 V > Udétection > 170 V), the device switches into relief mode.

The battery provides charge in automatic without interruption while switching. The relay "AC In Status" switches and the dry contact changes from rest to work. As soon as mains returns, the led switch off, the power supply provides the current operation and the MS122402 remains in battery charger.

4-2 "Battery FAULT"

Battery fault, the led "Batt FAULT" lights up : while starting if battery voltage is not adjusted according to the power supply one, the module goes to relief mode (no battery charge), the led "Battery FAULT" lights up to indicate the fault. The "Batt Status" relay switches and the dry contact changes from rest to work.

For safety reasons, the module remains configured that way, even if voltages remained conform.

To return to normal operation, it is necessary to disconnect the battery and the power supply and then to check compliance voltages before reconnecting.

The system also goes into safety mode with the led "Battery FAULT" enlighting in two other cases :

- overvoltage on the battery (14,5V for a battery of 12V and 29V for a 24V) due to a charge fault or a battery non adapted.
- excessive voltage difference between battery and power supply, exceeding 4V for a battery of 12V and 8V for a 24V.

On "normal" operation, (mains on, power supply working and battery connected), if the current required by the load is greater than that generated by the power supply, The battery will provide the additional within the limit of 2 amps. Beyond that, this operation is managed by default because the battery discharges; the led "Battery FAULT" lights up and the associated contact closes. Each 10 seconds, the led lights off and the contact opens (during 100ms) in order to test fault presence.

4-3 "Battery Invert"

In the case of battery reverse polarity, the load circuit remains disconnected; the led "Battery Invert" lights up. Reconnect the battery in the right direction to return to normal operation.

4-4 System Shutdown and "Bypass"

To avoid any damage of the battery during a prolonged sector absence, the module goes to safety mode (the system shutdown and the battery disconnects) if voltage decreases down to : 10,3 V for a battery of 12 V and 20,6 V for a 24 V.

After the shutdown due to battery discharge, the "Bypass" knob allows to restor output voltage, for example to unlock a system. Voltage will be present only while pressing the knob.

4-5 Table of faults and probably causes

Fault	Probable Cause
Led "AC Input FAULT" lighted	Mains absent or below 170 V
Led "Battery FAULT" lighted	Battery absente
	Battery highly discharged
	Battery overcharged
Led "Battery Invert" lighted	Supply voltage too high (or low) relative to the battery
	Current supplied by the battery > 2 A
	Battery connected in reverse

CAUTION : safety rules for batteries operation

Respect precautions below (non limited) applied to battery operation; a bad use can be dangerous and cause injuries, burns, fire or an explosion.

- Do not operate the battery in an environment above 40 °C. Faster deterioration.
- Do not use battery in the presence of corrosive gases
- Exposure can corrode contact surfaces, which results in unstable connections and avoid recharge or relief.
- Do not use a battery in a non ventilated local or nearby devices that generate sparks (contactors, relays or static charges) because charged, is able to produce flammable gases.
- Do not use batteries in areas where are present medical devices or other vital equipments, this may cause damages, fatal or non.
- Do not shunt the battery with a metal object.
- While installing the battery, do not drop it. Risk of leakage of electrolyte
- Never mix new and used batteries of different types and powers
- Unplug and replace the battery immediately in case of bad odor, anomalous noise, smoke, fluid leak or malfunction.
- Observe the self-imposed controls, laws and regulations regarding disposal of scrapping or collection (recycling) of batteries).

To cut the module in case of emergency, switch the mains circuit breaker of the power supply into "Stop" and disconnect the battery. If only the mains is shutdown, the system powered by the battery continues to function which may damage equipment or cause injury.

5. MAINTENANCE

No particular maintenance is required for this instrument. Avoid dust, moisture, shocks : your instrument will be grateful for that. In the case of replacing of the backup system MS122402, the battery or the power supply (not supply with the device), it is necessary to have a complete shutdown of the system, disconnect the battery and isolate the area 230V AC.

6. AFTER SALES SERVICE

During **ONE YEAR**, spare parts and workmanship are guaranteed, return costs are charged to the customer. Only devices returned with a dated purchasing invoice can be recovered by the guarantee. Any intervention carried out by unauthorized persons or organizations, shall void the guarantee

7.DECLARATION OF CONFORMITY ACCORDING TO ISO/IEC GUIDE 22 AND EN 45014

Manufacturer : ELC
 Address : 59 avenue des Romains 74000 Annecy FRANCE
 declares the product
 Name : backup system (DC Backup Block) Type : MS122402
 meets the following specifications :
 Safety : EN 60950:2000, NF S 61-940 (§ A4-A6) EMC : EN 61000-6-2:2001, EN 61000-6-4:2001
 Further informations :
 The product above is conformable to the requirements of the «Low voltage» directive 2006/95/CE and the «Electromagnetic Compatibility» directive 2004/108/CE.
 Annecy, January 2nd, 2010 H. CURRI Gérant